

MUCHEA BATTERY

Community Information Booklet

NEOEN



mucheabattery.com.au



Aniruddha Deshpande, Project Manager



contact@mucheabattery.com.au



1800 966 102

CONTENTS

About Neoen.....	1
Neoen case studies.....	3
What does a big battery look like?.....	5
Project lifecycle.....	6
What can a big battery do?.....	7
Muchea facts & figures.....	9
Muchea site location.....	10
We own & operate our projects.....	11
Community benefits.....	12
Frequently asked questions.....	13



GLOBALLY

The company is headquartered in Paris, France, and has four Australian offices – in Sydney, Adelaide, Canberra and Perth.

We operate across renewable energy technologies including solar, wind and storage in Europe, the Americas, Africa, and Australia.

Neoen's total capacity in operation and under construction is currently 4.8 GW and we are aiming for 10 GW by the end of 2025.

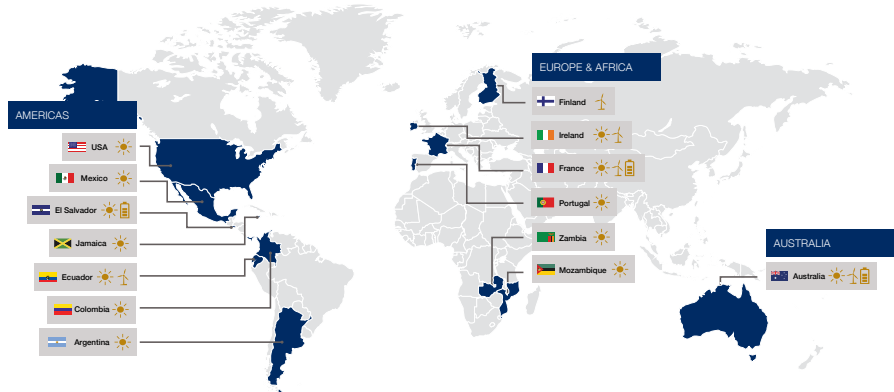

LOCALLY

Neoen Australia began operations in 2012. Over the last nine years the company has initiated the development of more than 2GW of solar and wind projects through organic growth, local partnerships and strategic acquisitions.



Neoen produce clean electricity from renewable sources such as sunlight and wind using mature, tried and tested technologies. We are also leaders in energy storage.

WORLD'S FIRST BIG BATTERY HORNSDALE POWER RESERVE

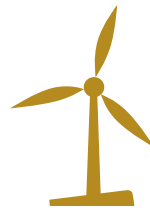

FIRST STAGE
TOOK LESS THAN
SIX MONTHS TO
BUILD

- 150MW Lithium-ion battery located next to Hornsdale Wind Farm
- Owned and operated by Neoen
- Installed and maintained by Tesla

- Provides grid stability services
- Saved SA energy consumers over \$150 million in its first two years
- Now testing grid scale inertia services in a world-first



REDUCES RISK
OF BLACKOUT
IN SOUTH
AUSTRALIA



DELIVERING CHEAPER ENERGY FOR INDUSTRY



LAVERTON STEELWORKS *VICTORIA*

Laverton Steelworks have agreed to take power from Neoen's 128 MW Numurkah Solar Farm under a 15-year deal. GFG Alliance's Executive Chairman said the deal would help lower energy costs at Laverton.



DEGRUSSA MINING *WESTERN AUSTRALIA*

DeGrussa is the largest off-grid solar battery storage project in Australia. It powers a gold and copper mine in remote WA. Commissioned in June 2016, it provides a solar and storage solution to the majority of the mine's daytime electricity requirements, offsetting up to 20% of total diesel consumption annually.



COLES *AUSTRALIA-WIDE*

Coles has signed an agreement that will source large-scale generation certificates (LGCs) from Neoen's portfolio of renewables located across New South Wales, Queensland, Victoria, South Australia and Western Australia. The deal will help Coles towards its target of 100% renewable energy by 2025.

DELIVERING CHEAPER ENERGY TO RETAILERS



ENERGY AUSTRALIA *COLEAMBALLY SOLAR FARM*

Providing energy output of 100 MW of the 150 MW solar farm for 12 years.



SIMPLY ENERGY *PARKES & GRIFFITH SOLAR FARM*

Providing 100% of the energy output of the two solar farms for 13 years.



ACT Government *HORNSDALE WIND FARM*

Providing 100% of the energy output of the 309 MW wind farm for 20 years, powering ACT's transition to 100% renewables.



WHAT DOES A BIG BATTERY LOOK LIKE?

HORNSDALE

POWER RESERVE

Our 150MW battery outside Jamestown, SA
co-located with Hornsdale Wind Farm



BULGANA

GREEN POWER HUB

Our 20MW battery near Bulgana, Victoria
located next to our Bulgana Wind Farm



PROJECT LIFECYCLE

PHASE 1: DEVELOPMENT

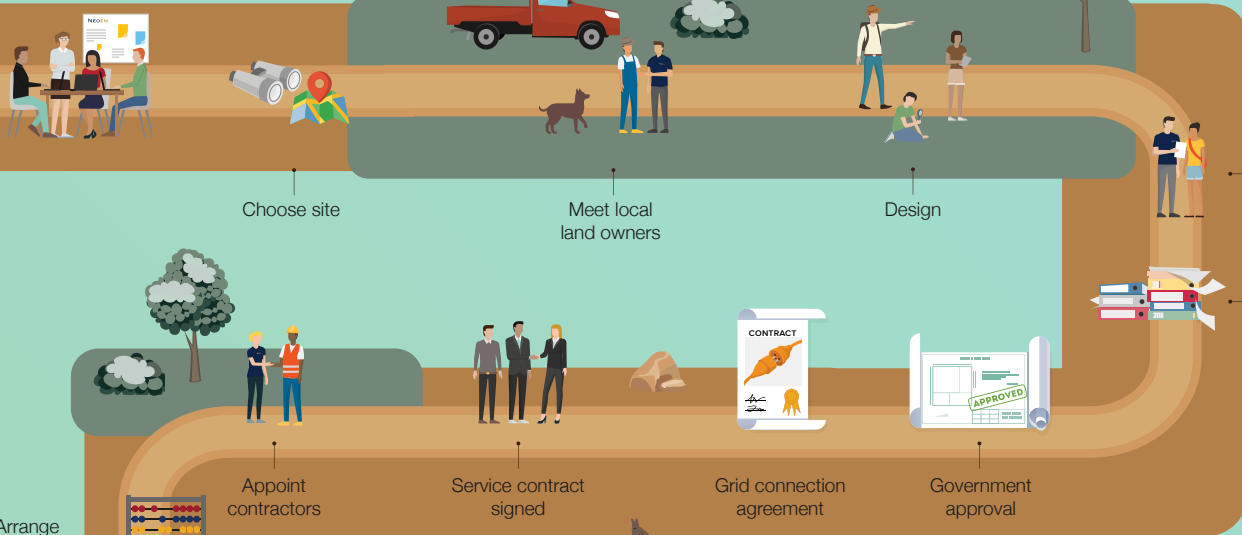

Community Info Day
Government submission

Arrange finance

PHASE 2: CONSTRUCTION



Regular community updates

PHASE 3: OPERATION



Testing & accreditation

Benefit-sharing initiatives

Operations & maintenance



Back to phase 1

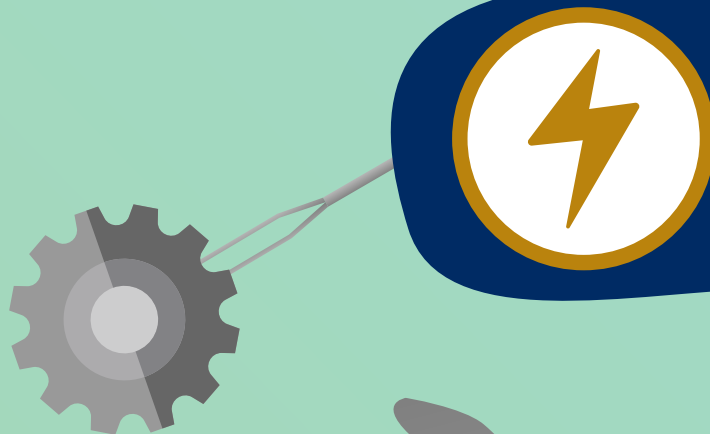

Basic function

When there is excess energy, the battery will charge.
When there is high demand for energy, the battery will discharge.

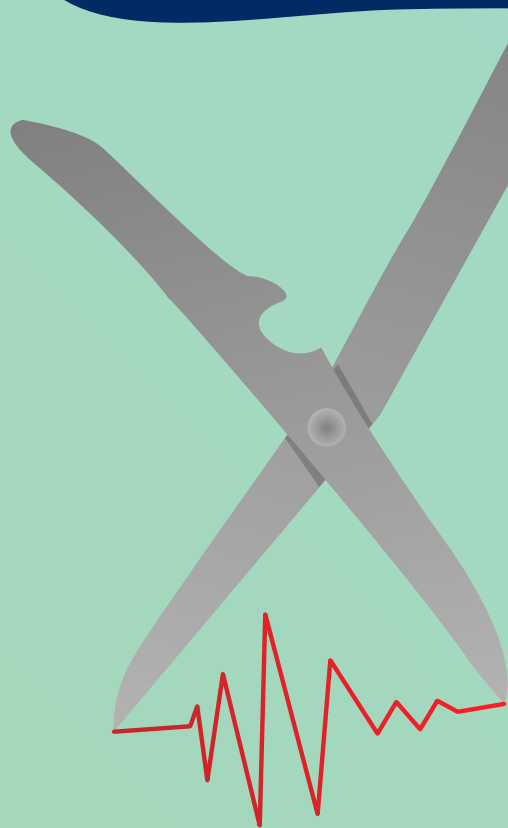

Frequency support

To maintain the stability of the system, the grid requires frequency control services. The battery discharges electrical power into the network in response to frequency changes. The battery can lower the cost of these service markets which results in lower electricity prices for everyday consumers.

BATTERY DO?

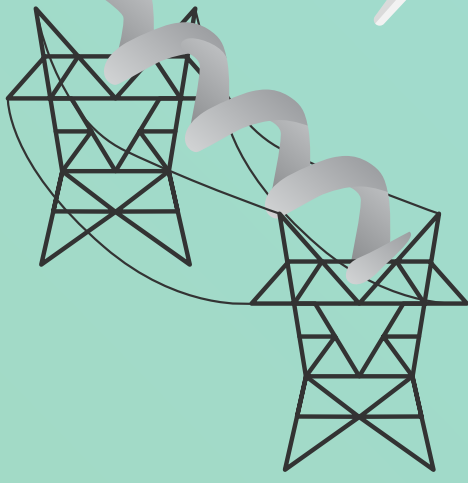
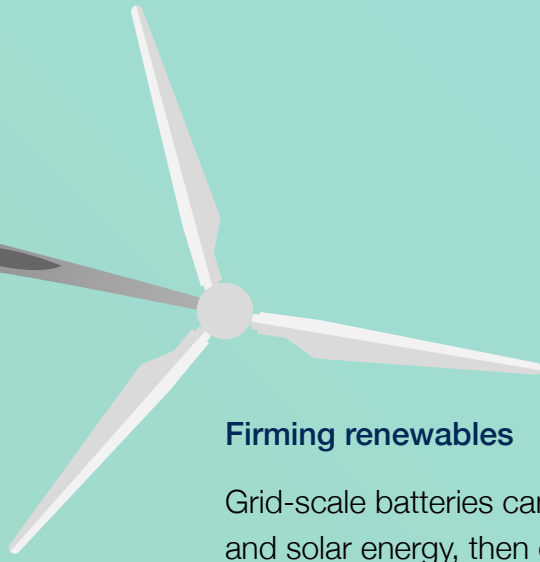

Inertia

As with vehicle suspension on an uneven road, inertia services are essential for stabilising the grid. The advanced power inverters associated with a big battery can emulate the inertia services that are currently provided by an ageing fleet of fossil fuel power plants. This service is currently being trialled at our Hornsdale Power Reserve.

Firming renewables

Grid-scale batteries can store wind and solar energy, then discharge it when the wind isn't blowing and the sun isn't shining. The Mueha Battery aims to be an essential component in the stable transition to clean electricity.

Transmission network support

Grid-scale batteries can provide dynamic millisecond responses so existing transmission lines can operate at full capacity. Like adding another lane to a freeway, the battery can unlock additional capacity on existing transmission networks – saving customers millions of dollars in expensive transmission line upgrades.

MUCHEA BATTERY FACTS & FIGURES



Up to
200MW
power capacity

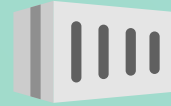

Up to
400MWh
energy storage



Up to
30,000x
more capacity than a household battery

BATTERY TECHNOLOGY

Battery packs are enclosed in custom designed, dust and waterproof 'cabinets' made of galvanised steel. Cabinet colour is white or light coloured to assist with heat management and each cabinet has its own internal thermal management system.

Will conform to electricity industry standards

Will use an industrial inverter to convert DC power to AC when discharging (vice versa when charging)

Battery cabinet

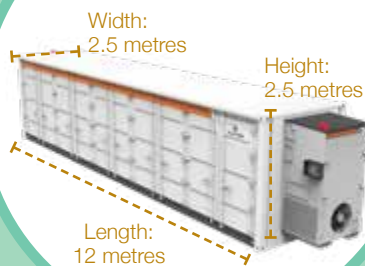

Likely to be lithium-ion battery packs enclosed in steel cabinets, similar to shipping containers

Will meet all safety and bushfire risk requirements

Battery brand to be determined

Inverter

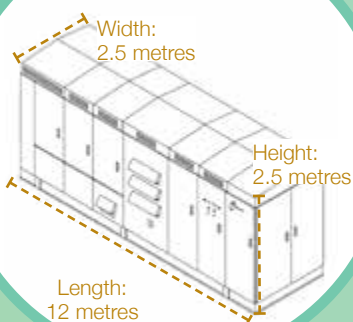

Inverters are made from galvanised steel, and may exist as one single 20ft container or a few outdoor cabinets on concrete slabs.

CHOOSING THE SITE

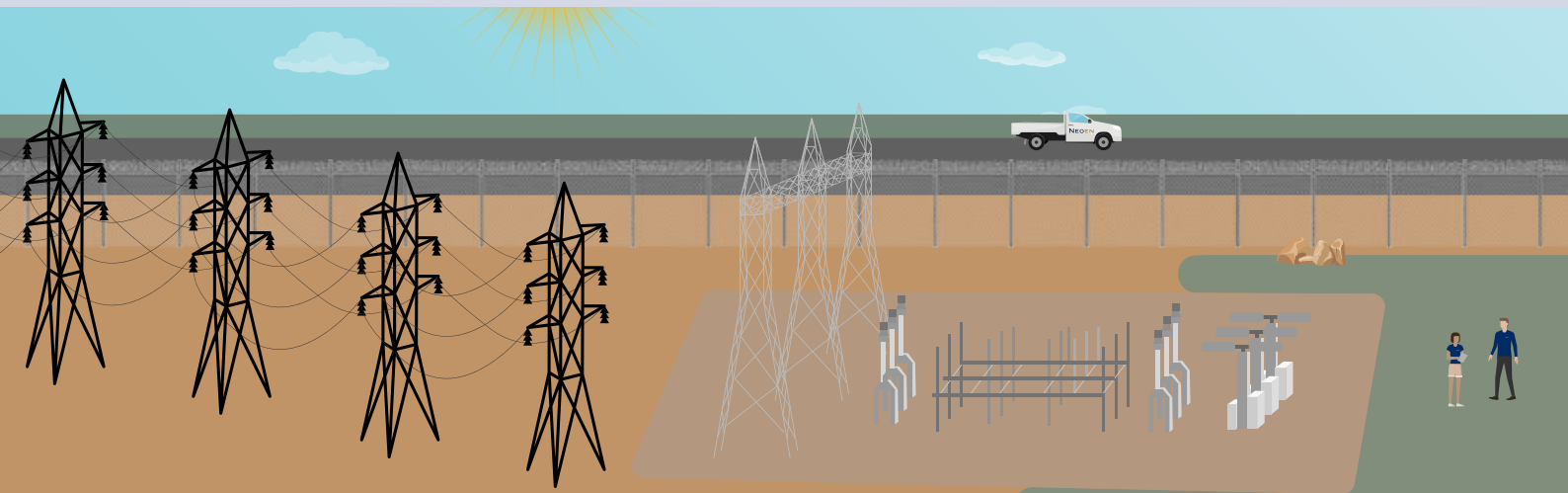

1) Good grid location

The Muchea Battery will be located approximately 2km north of Muchea – 43km north-east of Perth within the Shire of Chittering.

2) Proximity to substation

It will connect into the Muchea substation at 132kV. The advantage of the close proximity to the substation is that electrical connection infrastructure is minimised which increases the performance and minimises cost.

3) Site history

Studies of the proposed site location have found little to no presence of significant ecology systems, reducing potential impacts on the local environment.

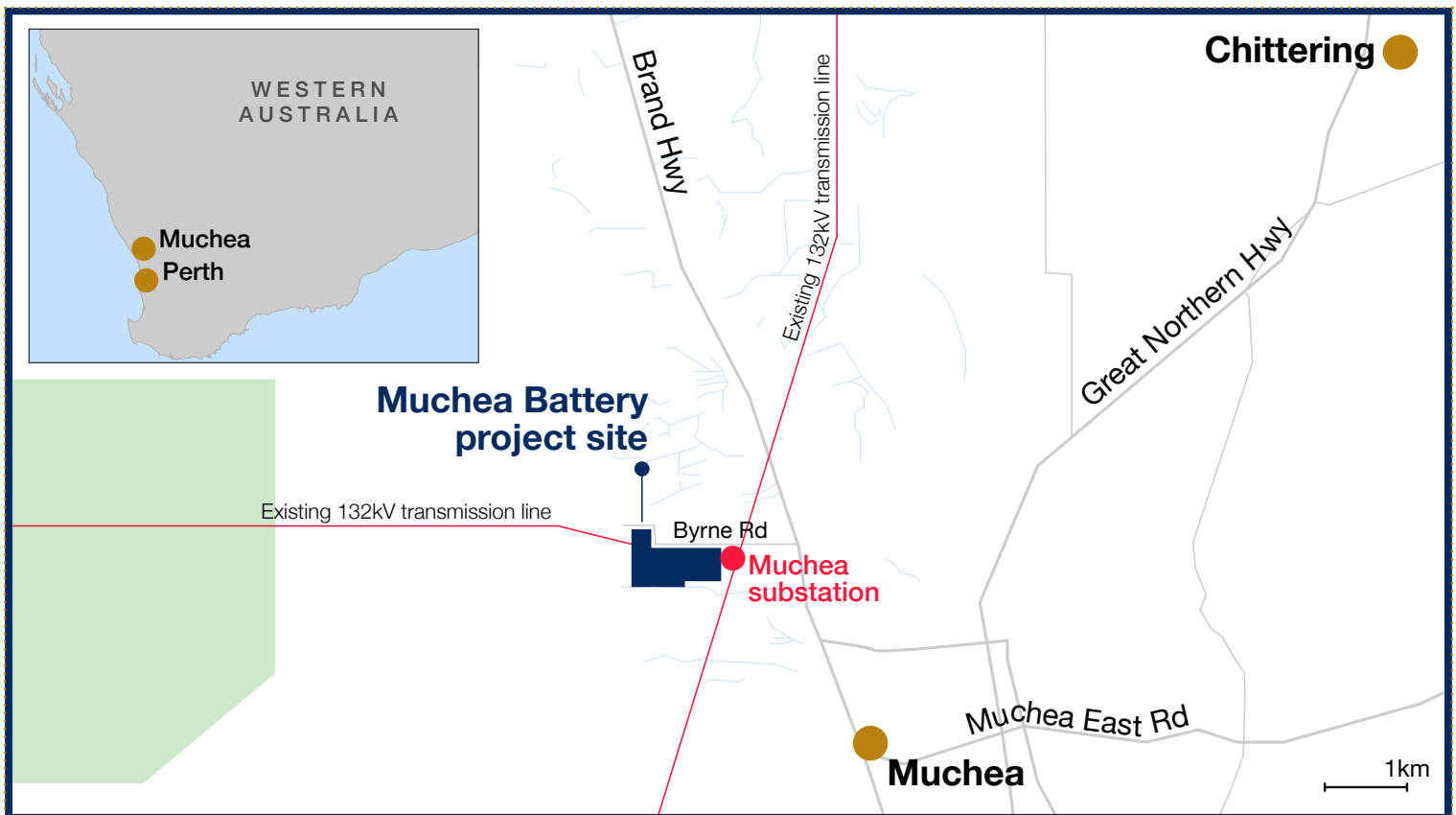

WE OWN & OPERATE OUR PROJECTS

Muchea Battery

The Muchea Battery will be managed from Neoen's 24/7 Operational Control Centre in the Canberra, which currently operates our 12 existing projects across Australia. This office coordinates with local maintenance contractors for safe, effective and compliant operations.

Neoen's Portfolio

Neoen develops renewable energy projects to own and operate them – not to on-sell them. With over 2GW of operating projects connected to Australia's National Electricity Market (NEM), our asset and operations team play an important role in managing our power plants.



Our Operational Control Centre oversees our interactions with the wholesale electricity market (WEM): a wholesale electricity market in the Southwest Interconnected System. The WEM commenced operation in September 2006. Its purpose is to supply electricity to homes and businesses in the South West of Western Australia efficiently and securely (through the South West Interconnected System or SWIS). Electricity retailers purchase electricity from generators either directly or indirectly through the WEM.

COMMUNITY BENEFITS



Community benefit fund

The funds would be allocated to local community projects through a competitive annual grants process.

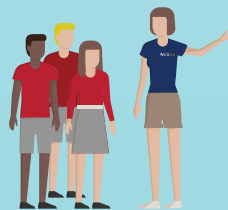

Educational resources

Develop educational resources for local schools to support learning about renewables and our future energy system.



Local tourism

Develop a local tourism initiative centred on batteries or renewable energy



Local jobs

Community co-investment is common overseas and just starting in Australia



Tell us your ideas

To submit your ideas, please fill out our online survey: [surveymonkey.com/r/mucheabattery](https://www.surveymonkey.com/r/mucheabattery)



ABOUT STORAGE

Q1. How long will it take to build the battery?

Construction of the Muchea Battery will take around 16 months.

Q2. How big will it be?

Once completed, the battery and associated infrastructure will cover up to 5 hectares of land. The battery cubicles are normally around 2.5 meters tall.

Q3. Where will it be located and why?

The Muchea Battery will be located near the existing Muchea Substation, approximately 2km north of Muchea.

The land is ideal because it is flat, in a rather isolated area and very close to the Substation.

The Muchea Battery will support in stabilizing the grid and the increasing number of renewable projects in WA.

Q4. What technology is being used for the project?

The Muchea Battery will utilise Lithium-Ion batteries and associated equipment from leading manufacturers. These manufacturers are selected through a separate competitive tender process.

In principle, the facility will be an orderly arrangement of battery cabinets, inverters and control systems including electrical and data cabling. The battery packs are enclosed in custom designed, dust and waterproof 'cabinets' made of steel. The cabinet colour will be white, or light coloured to assist with heat management and each cabinet has its own internal thermal management system.

Q5. What is the life cycle of the Battery?

Current battery technology comes with an industry-leading 20-year warranty. The batteries will still retain the majority of their capacity during this period and will be capable of operating beyond it depending on market conditions and other factors.

Q6. How does it work?

The Muchea Battery will store energy in times of high production and release energy in times of high demand, similar to how a battery on a home solar system works. It will also help to stabilise the grid in a few different ways – it has an emergency response mode to prevent blackouts and it can maintain voltage and frequency levels.

Q7. What are the benefits of battery energy storage?

In making the transition from fossil fuels to renewables, the ability to store and dispatch energy will play a key role. Pumped hydro is an example of longer-term storage that is suitable for storing energy and releasing it over days or weeks. However, pumped hydro has a relatively slow 'ramping' time and is less suitable for providing rapid-response services to grid contingency events such as outages or heat waves (with high demand created by air-conditioning). Battery storage, such as lithium-ion technology, fills this key short-term response role.

These are some of the functions a grid-scale lithium-ion battery may be expected to perform:

- Network security services including Frequency Control Ancillary Services, and Network Loading Control Ancillary Services
- System Restart Ancillary Services
- Arbitrage (spot market trading)
- Peak shaving
- Block/load shifting
- Renewable firming and smoothing
- Virtual inertia

Many of these services have been provided by coal and gas generators in the past, but as their business models become unviable and they close down, battery energy storage can, and is, being used to deliver these critical services.

ECONOMIC

Q8. Who will pay for it?

The project will be privately financed by Neoen.

Q9. How is the battery reducing costs for consumers?

Muchea Battery can reduce costs for consumers in three ways:

1. supporting more wind and solar, which are now the cheapest forms of power
2. increasing competition in ancillary markets which lowers (or reduces) electricity prices
3. helping to avoid blackouts and the associated costs

Q10. Will local jobs be created?

It is expected the Muchea Battery will create a significant volume of construction jobs and a number of full-time ongoing positions.

We will also provide opportunities for local suppliers, businesses, schools, and community groups.

LOCAL

Q11. I live nearby – what impact will this have on me?

During construction, we expect some localised traffic, noise, and dust impacts. However, we will be managing these to minimise them as much as possible. Following installation, the battery will be visible at the site and will look like an enclosure of white containers.

Q12. How will construction impact the surrounding area?

As with most projects of this size, there will be some impacts during construction. We will work with the community, neighbours, and council to minimise these impacts.

Q13. How can I have my say on the project?

We will be working with the community throughout the project to understand local concerns and aspirations, and ensure we minimise any impacts. We encourage the community to provide feedback through completing the survey.



SAFETY AND ENVIRONMENT

Q14. What approvals are required for the project?

The project requires a development permit from the Shire of Chittering and Development Assessment Panels

Q15. Will the battery increase the risk of fire?

The Muchea Battery will meet all relevant standards for fire safety, and we are working with the local fire authority to ensure the project also meets their requirements.

Q16. What happens to the batteries when they reach the end of their life?

We make a commitment that all above-ground infrastructure will be removed, and the site rehabilitated when the project ceases to operate. After removal, a large percentage of the material in the batteries will be reclaimed or recycled; over 60% of materials especially critical minerals will be recovered for re-use.

Q17. Are there any health risks?

The Muchea Battery is using similar technology to the batteries that are being increasingly installed in homes, just on a larger scale. There are no known health risks associated with properly maintained large-scale battery installations.

Q18. Is the project reducing air quality?

Monitoring of dust levels during construction is a basic requirement of each project. Dust generating activities are assessed during windy conditions and are stopped and rescheduled where adequate control of dust generation cannot be achieved.

Visual observation of machinery is undertaken during site inspections in addition to daily pre-start checks which ensure all machinery has appropriate emission control devices, is in good working order and is maintained correctly.



MUCHEA

BATTERY

 mucheabattery.com.au

 Aniruddha Deshpande, Project Manager

 contact@mucheabattery.com.au

 1800 966 102